

MMS 6120

Dual Channel Bearing Vibration Monitor

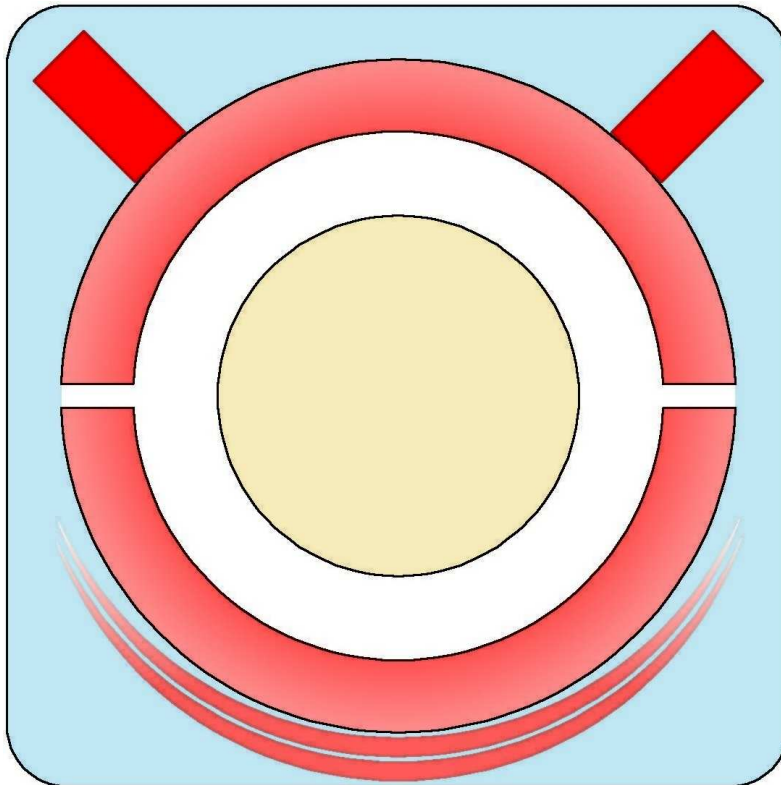

- Part of the MMS 6000 System
- Replaceable during operation; stand alone use possible, redundant supply inputs
- Extended selfchecking facilities; built in sensor-self-test facilities; password protected operating levels
- For use with electrodynamic vibration type transducer PR 9266 /... to PR 9268 /...
- Readout of all measured data including selectable harmonic order values and phaseangles via RS 232 / RS 485
- RS 232 interface for local configuration and readout
- RS 485 interface for communication with epro's Analysis and Diagnostic System MMS 6850

Applications:

The **Dual Channel Bearing Vibration Measuring Module MMS 6120** measures absolute bearing vibrations – using outputs from electrodynamic vibration velocity type sensors – according to:

V_{RMS}	(V_{eff}) true RMS vibration velocity
S_{op}	vibration displacement zero to peak
S_{pp}	vibration displacement peak to peak

The design of the modules meets the common international standards e. g. VDI 2056. These measurements are recommended among and together with others to build up Turbomachine Protection Systems and provide the inputs requested by Analysis and Diagnostic Systems, Field Bus Systems, Distributed Control Systems plant/host computers and networks as e. g. WAN/LAN, Ethernet.

Such Systems are also suitable to build up systems to increase the performance and efficiency, the safety of operation and extend the lifetime of machines such as steam-gas-hydro turbines as well as compressors, fans, centrifuges and other turbomachines.

Technical data:

<p>Sensor inputs: Two independent inputs for electrodynamic vibration velocity sensors. Sensor inputs are of the differential type, galvanically separated from the power supply. Input resistance: > 100 kOhm Input voltage range: -5 ... +15 V dc</p> <p>Measuring ranges: Continuously adjustable with the configuration software. Min. dynamic input voltage: 311 mV_{pp} for 100 % measuring range Max. dynamic input voltage: 9500 mV_{pp} for 100 % measuring range (allowing measuring ranges: V_{RMS} = 5 ... 100 mm/s corresponding with ±25 ... ±500 µm vibration displacement for the transducers PR 9266 / ... PR 9268 / ...)</p> <p>Frequency range: 10...1000 Hz (according to VDI 2056 /</p>	<p>DIN 45666 / ISO 3945) Filter characteristics accordingly Other frequency ranges selectable from 5/10 ... 50 ... 1000/1600 Hz.</p> <p>Lifting coil current: For each of the two input channels a separate, buffered lifting coil current output is available to compensate the mechanical sag of the transducer; these outputs are galvanically separated from all the system voltages as well as from the system supply voltage and they are open and shortcircuit proof. Available current: 0 ... 8 mA; configurable in steps of 40 µA. accuracy: ± 0,5 % fsd / + 0,5 % of configured value. Max. permissible load: 3,4 kOhm at 8 mA; 13,6 kOhm at 2 mA.</p> <p>Control inputs: Common logic binary inputs for both channels: To select optocoupler mode: "alert"; make or brake mode</p>	<p>"danger"; make or brake mode. Channel or module inhibit. Measuring range multiplication to change the alarm levels during start-up and cast-down; adjustable with a factor of 1,0000 ... 4,9999. 24 V logic Input resistance: > 10 kOhm</p> <p>Keypulse input: Keypulse (1 puls per rev.) input for system control (only requested for order analysis purposes) 24 V logic Input resistance: > 10 kOhm Pulsduration: min. 10 microsec. (slope triggering)</p> <p>Voltage inputs: Two, one for each channel Not used in standard applications. 0 ... 10 Volts Input resistance: >100 kOhm Resolution: 10 bit</p>
--	---	---

Measuring modes:

<p>Measuring modes: (Each channel to be individually configured) Different measuring modes can be configured via an externally connected (RS 232 connector on the frontpanel of the module) laptop or via the communication bus. Measuring modes can be changed at any time during operation (function of the module is interrupted for approx. 15 sec.).</p>	<p>Measuring modes for each individual channel: Measurement of absolute bearing vibration either horizontal, vertical or axial: V_{RMS} according to VDI 2056 S_{op} S_{pp} Measurements according to DIN 45666 and ISO 3945</p>
--	---

Programmable measuring parameters:

<p>Measuring range Engineering units Sensorsensitivity: Warning and alarm levels Filter frequency ranges: high pass low pass</p>	<p>Channel identification: By means of KKS numbers or a freely selectable name. Order analysis functions: The following parameters derived from an order analysis carried out in the</p>	<p>modules built in microcontroller are available via the RS 485 / RS 232 communication bus: Values of 3 selectable harmonics (out of 1/4, 1/2, 1 to 10) and phase-angles of the same harmonics.</p>
--	--	--

Limit supervision:

<p>For each channel two separately adjustable alarm levels are available. The alarm functions can be blocked by the channel clear/circuit fault function or by an external input. After downloading of a new configuration the alarms are blocked for 15 sec. settling time.</p>	<p>Adjustable range: 5...100 % of fsd. Resolution and reproducibility: 1 ‰ of fsd Delay time: 1-2-3-4-5-6 sec. selectable Switching characteristic: with increasing signal level</p>	<p>Switching hysteresis: 5 % of fsd (only effective during decreasing signal values) Outputs: Via potential free opto couplers on the rear strip connector. U_{max} = 48 V dc I_{max} = 100 mA</p>
--	--	--

Module and sensor supervision:

Channel clear/circuit fault sensing system; the internal modul supervision circuitry continuously supervises the following functions:

Sensor signal is within a preset window.
Cabling between sensor and modul is ok (no shortcircuit, no break).

System supply voltages are within preset windows.

Configuration and parameter settings are correct.

Measuring range not overloaded.

Internal temperature not overloaded.

System watch dog.

During changing from a sensor malfunction into the ok status or after switching on the modul a delay time of 15 sec. is operable.

"Channel clear" is visualised on the front of the module by means of a green LED; this LED switches off during a "channel fault"; during the delay time the LED flashes.

The channel status is also indicated via a

binary output, separately for each of the two channels.

$U_{max} = 48 \text{ V dc}$

$I_{max} = 100 \text{ mA}$

The reasons for a "channel fault" indication can be read out via the communication buses; which enables service personnel to take immediate corrective measures.

Signal outputs at the connecting strip:

Terminal strip on rear side:

acc. to DIN 41 612 , version F 48 M
RS 485 communication interface.

Two independent current outputs:

One for each channel; outputs are proportional to the selected operating mode.

0/4..20 mA; configurable, open- and shortcircuit proof

Permissible load: < 500 Ohms

Accuracy: 16 bit resolution; $\pm 1 \%$ of full range

Settling time: 0 ... 10 sec.; configurable in increments of 1 sec. separately for each channel.

Two independent voltage outputs:

One for each channel; outputs are proportional to the selected operating mode (e. g. shaft vibration amplitude $S1_{op}$)

0 ... +10 Volt, open and shortcircuit proof

Load resistance: > 10 kOhm

Resolution: 8 bit

Two independent voltage outputs:

One for each channel; proportional to the AC part of the signal are available; one for each channel.

open and shortcircuitproof.

Nominal range: 0 ... 20 V_{pp}

Permissible load: > 10 kOhm

Frequency range: 0,1 Hz...5 KHz

($\pm 20 \%$ / - 3 dB)

Operating elements at the module front:

Two independent voltage outputs:

identical to the transducer system inputs are available via SMB sockets; one for each channel.

Range: $\pm 10 \text{ Volts}$

Load: > 100 kOhm

Frequency range: 0,1 ... 5 KHz; $\pm 20 \%$

2 green LED's:

Indicate "channel clear" separately for channel 1 and channel 2.

2 red LED's:

Indicate "alert" and "danger" separately for channel 1 and channel 2.

1 Mini-DIN diode type socket:

As input for the configuration cable RS 232 communication interface.

Handle:

To pull out or insert modul with identification labelling facility

Power supply:

Redundant supply input via two supply inputs, decoupled via diodes. At least one supply input is required for the supply of the module.

Supply voltage:

18...24...31.2 V DC

according to IEC 654-2, class DC4

Power consumption:

max. 6 W (max. 250 mA at 24 V)

Other supply voltages can be realized with additional system power supplies.

System design:

At standalone operation, unlimited number of modules.

Max. 31 modules / 62 channels may be operated at one RS 485 bus

If more modules / channels are necessary, e.g. with an MMS 6815, another RS 485 bus must be installed.

Environmental conditions:

Protection class:

Module: IP 00 according to DIN 40050
Front plate: IP21 according to DIN 40050

Climate conditions:

according to DIN 40040 class KTF
operating temperature range:

0...+65°C

Temperature range for storage and transport:

-30...+85°C

Permissible relative humidity:

5...95%, non condensing

Permissible vibration:

according to IEC 68-2, part 6

Vibration amplitude:

0.15 mm in range 10...55 Hz

Vibration acceleration:

16.6 m/s² in range 55...150Hz

Permissible shock:

according to IEC 68-2, part 29
peak value of acceleration:

98 m/s²

nominal shock duration:

16 ms

EMC resistance:

according to EN50081-1 / EN50082-2

Dimensions:

PCB/EURO card format acc. to
 DIN 41494 (100 x 160 mm)
 Width: 30,0 mm (6 TE)
 Height: 128,4 mm (3 HE)
 Length: 160,0 mm
 Net weight: app. 320 g
 Gross weight: app. 450 g
 incl. standard export packing
 Packing volume: app. 2,5 dm³
 Space requirements:
 14 modules (28 channels) fit into each
 19" rack

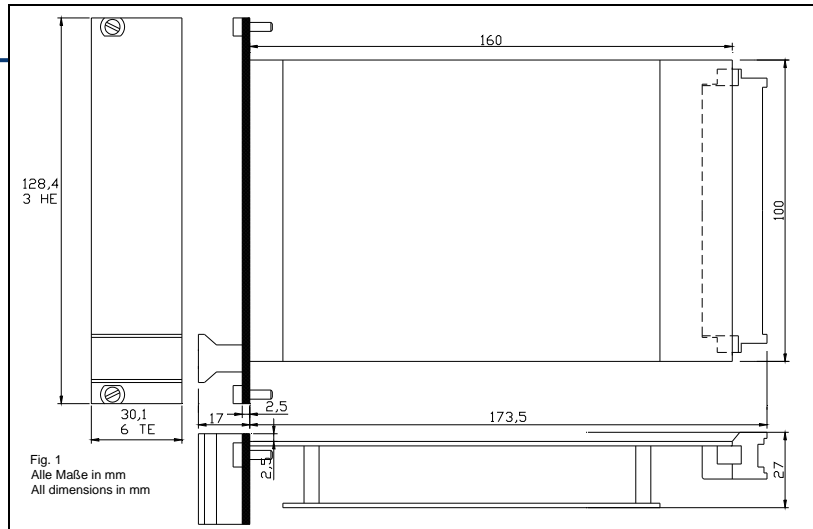

Requirements on configuration PC:

Configuration of modules is made via the RS 232 interface on the module front or via the RS 485 bus by means of a computer (laptop) with the following minimum specifications:

Processor: 486 DX, 33 MHz
Interfaces: one free RS 232 interface (COM 1 or COM 2) with FIFO type 156550 UART

Capacity of fixed disk: min. 5 MB
Required working memory: min. 620 KB
Operating system: MS DOS Version 6.22 or higher or WIN® 95/98 or NT 4.0

Connection diagram:

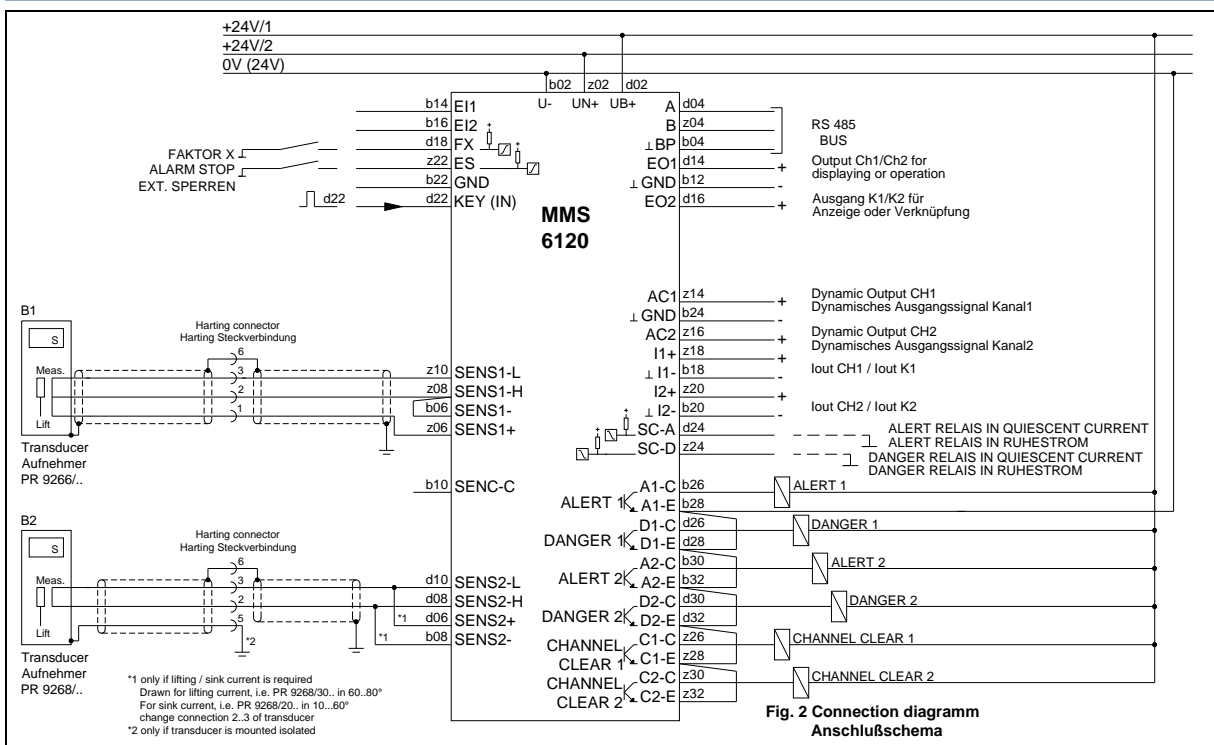

Order number:

MMS 6120	Dual Channel Bearing Vibration Monitor.....	9100 – 00002
MMS 6910 W	Operating accessories	9510 – 00017
	consisting of: operating and installation manual, configuration software and various connection cables	

The F48M mating connector has to be ordered separately depending on the intended wiring technology.

© epro GmbH
 Jöbkesweg 3 D-48599 Gronau
 Tel. +49 (0) 2562/709-245
 Fax +49 (0) 2562/709-255

Further Information:
 Internet: www.epro.de
 E-Mail: info@epro.de



6010 – 00002 07/05 Reh
 Printed in Germany. Due to continued research and product development epro reserves the right to change these specifications without notice.