

DeltaV™ M-series Traditional I/O



The DeltaV™ I/O subsystem is easy to install and maintain.

- Decreases capital equipment costs
- Decreases installation time and expense
- Increases productivity
- Increases process availability

Introduction

Traditional I/O is a modular subsystem that offers flexibility during installation. It's designed to be installed in the field, near your devices. Traditional I/O is equipped with function and field wiring protection keys to ensure that the correct I/O card is always plugged into the corresponding terminal block. Modularity, protection keys, and plug-and-play capabilities make DeltaV™ Traditional I/O a smart choice for your process control system.

Benefits

Decreases capital equipment costs

Full system modularity: The Traditional I/O subsystem was designed with your investment in mind. All components are fully modular and may be installable under power. You add I/O interface carriers and I/O interfaces in groups of 4, 8, 16, or 32 channels as you need them. The modular design enables you to purchase the exact amount of I/O cards, 8-wide or 4-wide carriers, power/ controllers, and 2-wide carriers you need and add more DeltaV I/O as your system grows.

Reduced system footprint: The DeltaV system's state-of-the-art form factor design of the I/O components enables you to mount the I/O interface carrier in a junction box in the field so you significantly reduce the footprint of your equipment and increase valuable control room space for other uses.

Installation: Save on wiring expenses by installing Classic Instrumentation in the field, near the actual field devices. Mounting the controller with the I/O further reduces your wiring expenditures by eliminating the need for long runs of multi-cores. The integrated design of the Traditional I/O subsystem can eliminate the need for marshalling panels. This saves you even more in your total capital costs.

The provision of in-line fuses and bussed power saves on installation costs compared with external fuses and power distribution.

Decreases installation time and expense

Plug-and-play installation saves money: All Traditional I/O components plug into the I/O interface carrier. You can install the I/O interface carriers to manage anticipated growth and postpone the I/O interfaces until you're ready to install your additional field devices.

Phased installation saves time: As soon as you mount the I/O interface carrier, you're ready to begin installing the field devices. I/O terminal blocks plug directly onto the I/O interface carrier. There is no need to have the I/O cards installed.

Keys: Traditional I/O interfaces and terminal blocks have I/O function keys. These keys ensure that the correct I/O card is always plugged into the corresponding terminal block. It's incredibly easy to use and gives you time to do more.

This design enables you to initially install Traditional I/O quickly and efficiently. When you need to replace an I/O card, the function key design ensures that you will always install it correctly. This keying system provides a safety measure by preventing the wrong I/O interface's being installed.



Traditional I/O terminal block.

Increases productivity

Real-time, online equipment additions: Online addition of new I/O interfaces means your process does not get interrupted. As new equipment is added, the DeltaV Explorer acknowledges it and assigns it basic configuration.

Increases process availability

1:1 Redundancy for Traditional and HART I/O cards: DeltaV redundant I/O uses the same Series 2 I/O cards as non-redundant I/O. This allows you to leverage your investment in installed I/O and in I/O spares. No additional configuration is needed when using a redundant channel. The redundant terminal blocks provide the same field wiring connections as simplex blocks, so there is no extra wiring needed.

Autosense of redundancy: DeltaV autosenses redundant I/O, which greatly simplifies the task of adding redundancy to the system. The redundant pair of cards is treated as one card in the system tools.

Automatic Switchover: Should a primary I/O card fail, the system automatically switches to the "standby" card without user intervention. The operator is given clear notification of a switchover at the operator display.

Product Description

The Traditional I/O subsystem includes:

- I/O interface carrier (a DIN rail surface mounted) on which all I/O related components are installed.
- Bulk AC to 24V DC power supply for field devices.
- An I/O interface consisting of an I/O card and an I/O terminal block.
- A variety of analog and discrete I/O cards enclosed in a common form factor that easily plugs into the I/O interface carrier.
- A variety of I/O terminal blocks mounted on the I/O interface carrier that can be pre-wired before I/O card installation.

I/O Cards

A variety of analog and discrete I/O cards are available to meet your specific requirements. The following cards support simplex or redundant installation:

- AI 4-20 mA HART 8 channels
- AO-4-20 mA HART 8 channels
- DI, 24V DC Dry Contact, 8 channels
- DO 24V DC High-Side, 8 channels



A Traditional I/O card easily plugs into an I/O carrier.

- AI (Plus) 4-20 mA HART, 16 channels
- AO (Plus) 4-20 mA HART, 16 channels
- DI (Plus) 24V DC, Dry Contact, 32 channels
- DO (Plus) 24V DC, High-Side, 32 channels

The following I/O cards are supported in simplex format to meet your field wiring needs.

- AI Isolated, 4 channels
- RTD, 8-channels
- Thermocouple, 8 channels
- Millivolt, 8 channels
- DI, High Density, 32 channels
- DI 24V DC Isolated, 8 channels
- Multi-Function, 4 channels (Isolated DI)
- Sequence of Event, 16 channels (DI 24 V DC)
- DI 120V AC Low Side Detection, 8 channels
- DI 120V AC Isolated, 8 channels
- DO 24V DC Isolated, 8 channels
- DO 120/230V AC High-Side, 8 channels
- DO 120/230 Isolated, 8 channels

All I/O cards are enclosed in a common form factor that plugs into the I/O interface carrier. The housing is clearly labeled with the enclosed I/O card type. All cards have power and internal error indicators. Eight-channel cards have clearly visible channel status LEDs.

All cards meet ISA G3 corrosion specifications by the careful selection of superior electronic components and the use of conformal coating.

Pulse Counters are available on most DI cards. The supported maximum frequency varies from 0.1 Hz on AC signals to 75 or 120 Hz on 24V DC inputs. For higher pulse counts, up to 50 KHz, use the Multi-Function card's high speed pulse input.

The DeltaV system provides control module level time stamping for log events and alarms. For greater event resolution, the 16-channel Sequence-of-Events DI card can provide signal driven events to a resolution of +/- 0.25 ms per card, or within 1 ms per controller. Please refer to the Sequence-of-Events PDS for more information on Sequence-of-Event data collection and system options for this feature.

I/O Card Redundancy

Redundant I/O cards are available for critical applications. The same card can be used in simplex or redundant applications. When installed on a two-wide redundant terminal block, the cards are recognized as a redundant pair by the controller. The controller scans each card and determines which card is acting as the active interface. When a fault is detected, the system automatically switches to the standby I/O card.

DeltaV Control modules reference simplex and redundant I/O channels identically and there is no special configuration required to take advantage of redundancy.

Switchover of a redundant I/O card is completed within two scans of the I/O bus. Make-before-break contacts ensure digital field instruments remain powered and the process is undisturbed. Analog output signals are briefly driven by both cards for < 5 ms during switchover of the card.

Hardware Alerts automatically report hardware integrity errors for both the primary and secondary cards. Any event that causes a switchover is also reported automatically through the system hardware alerts and is logged in the Event Chronicle.

Events that can cause a switchover include.

- Hardware failure within the active card.
- Communications failure between the active card and the controller.
- Detection of a fault in the field wiring.

A switchover may also be initiated from the diagnostics explorer, and the health and status of both cards and their channels are available in the diagnostics explorer.

The system automatically commissions a new standby card. In safe areas, failed cards can be replaced under power. In hazardous areas, appropriate installation procedures must be followed.

Hardware Specifications

Common Environmental Specifications for all I/O Interfaces	
Category	Specifications
Operating Temperature*	-40 to 70°C (-40 to 158°F)
Storage Temperature	-40 to 85°C (-40 to 185°F)
Relative Humidity	5 to 95%, non-condensing
Airborne Contaminants	ISA-S71.04-1985 Airborne Contaminants Class G3 Conformal coating
Protection Rating	IP 20
Shock	10 g ½-sine wave for 11 ms
Vibration	1 mm peak-to-peak from 5 to 16 Hz; 0.5 g from 16 to 150 Hz
Dimensions	H 10.7 cm (4.2 in.) W 4.1 cm (1.6 in.) Depth 10.5 cm (4.1 in.)

*Operating any electronics at the higher end of its temperature range for long periods of time will shorten its expected lifetime, see *Effects of Heat and Airflow Inside an Enclosure White Paper* for more information.

Analog Input I/O Cards

Specifications for HART AI-Card, 8-channel, 4 to 20 mA	
Number of Channels	Eight
Isolation	Each channel is optically isolated from the system and factory tested to 1500V DC.
Nominal Signal Range (span)	4 to 20 mA
Full Signal Range	1 to 22.5 mA, with over range checking
LocalBus Current (12V DC nominal) per Card	Simplex: 120 mA typical, 150 mA maximum Redundant: 175 mA typical, 250 mA maximum (per card)
Field Circuit Power per Card	300 mA maximum at 24V DC (+10%)
Accuracy Over Temperature Range	0.1% of span
Resolution	16-bits A/D converter
Repeatability	0.05% of span
Roll-off Frequency	-3 dB at 2.7 Hz, -20.5 dB at ½ the sampling frequency
Calibration	None required
Optional Fuse	2.0 A
Communications Support	HART pass-through for AMS Device Manager Field device variable and status reporting for control functions.
Hart Scan Time	600 – 800 ms (typical) per enabled channel

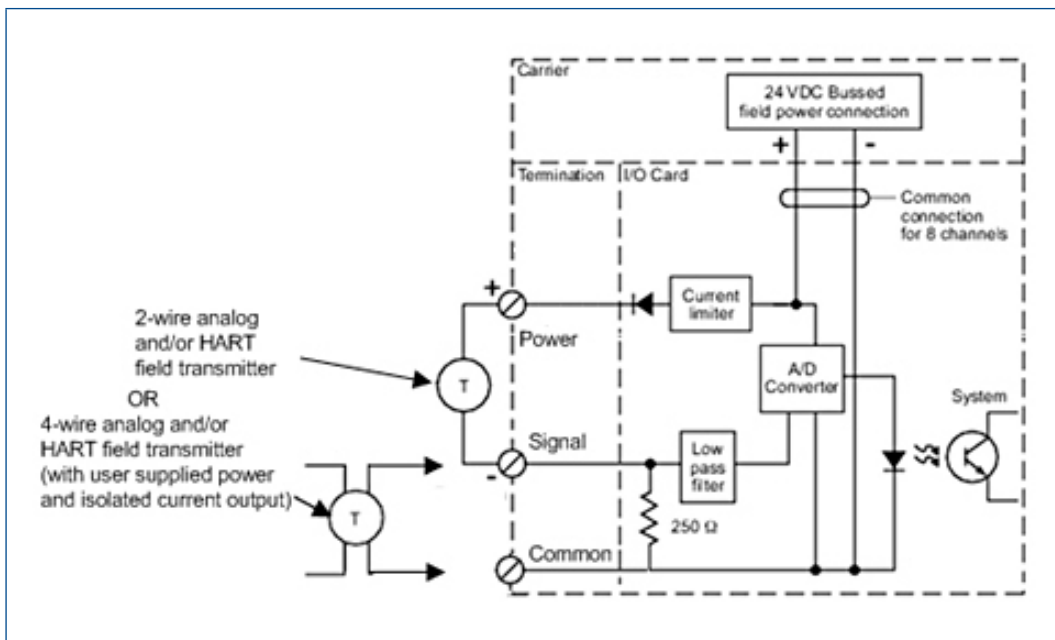

Simplified circuit and connection diagram for simplex AI card, 8-channel, 4 to 20 mA, HART.

Specifications for AI (Plus) Card, 16-channel, 4 to 20 mA, HART	
Number of Channels	16
Input Sensor Types	4 to 20 mA (span), 2-wire
Full Signal Range	2 to 22 mA, with over range checking
Transmitter Power	13.5 V minimum at 20 mA (max current limited at 29 mA)
Accuracy Over Temperature Range	0.2% of span
Repeatability	0.05% of span
Resolution	16-bit A/D converter
Roll-off Frequency (Anti-aliasing)	-3 dB at 2.7 Hz; -20.5 dB at 20 Hz
Calibration	None required
Local Bus Current per Card (12V DC nominal)	Simplex: 85 mA typical, 150 mA maximum Redundant: 110 mA typical, 200 mA maximum
Field Circuit Power per Card	500 mA maximum @ 24V DC (+/-10%)
Isolation	Each channel is optically isolated from the system and factory tested to 1000V DC.
HART Communications Support	HART pass-through for AMS Device Manager. HART variable and status reporting for control functions.
Hart Scan Time	600 – 800 mS (typical) per enabled channel

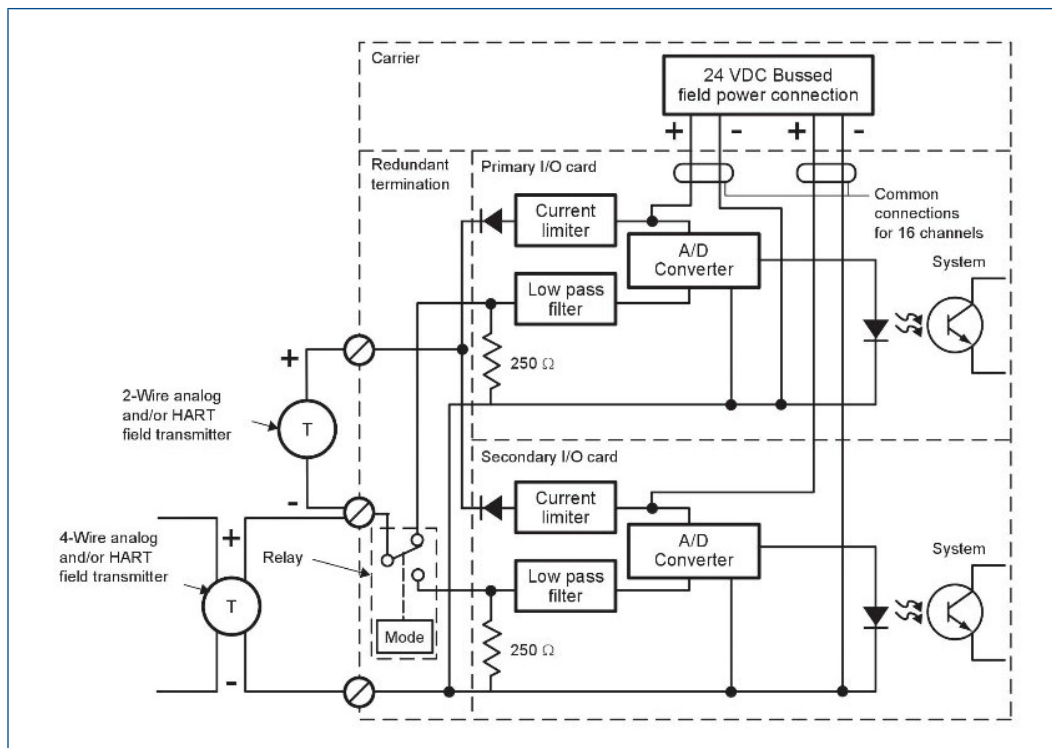

Simplified circuit and connection diagram for redundant AI Plus card, 16-channel, 4 to 20 mA, HART.

Specifications for RTD Input Card, 8-channel	
RTD Channels per Card	Eight
Sensor Types	2 wire, 3 wire, or 4 wire
Sensor Configuration	Resistance, Pt100, Pt200, Pt500, Ni120, Cu10, User Defined
Full Scale Signal Range	See Table below
Accuracy	See Table below
Repeatability	0.05% of span
A/D Resolution	16-bit
Calibration	None required
Units	°C, °F
Sensor Excitation Current	100 μ A
Common Mode Rejection	120 dB at 50/60 Hz
Common Mode Impedance	> 10 mega ohms
LocalBus Current (12V DC nominal)	160 mA
Open Sensor Detection Time	1 second
Open mV Lead Detection Time	15 seconds

RTD, ohms Sensor Type Specifications					
Sensor Type	Full Scale	Operating Range	25°C Reference Accuracy	Temperature Drift	Resolution
Resistance	0 to 2,000 Ω	0 to 2,000 Ω	$\pm 6.2 \Omega$	$\pm 0.112 \Omega/^\circ\text{C}$	$\sim 0.02 \Omega$
Pt100	-200 to 850°C	-200 to 850°C	$\pm 0.5^\circ\text{C}$	$\pm 0.018^\circ\text{C}/^\circ\text{C}$	$\sim 0.05^\circ\text{C}$
Pt200	-200 to 850°C	-200 to 850°C	$\pm 0.5^\circ\text{C}$	$\pm 0.012^\circ\text{C}/^\circ\text{C}$	$\sim 0.05^\circ\text{C}$
Pt500	-200 to 850°C	-200 to 850°C	$\pm 3.5^\circ\text{C}$	$\pm 0.063^\circ\text{C}/^\circ\text{C}$	$\sim 0.18^\circ\text{C}$
Ni120	-70 to 300°C	70 to 300°C	$\pm 0.2^\circ\text{C}$	$\pm 0.006^\circ\text{C}/^\circ\text{C}$	$\sim 0.02^\circ\text{C}$
Cu10	-30 to 140°C	-30 to 140°C	$\pm 2.0^\circ\text{C}$	$\pm 0.157^\circ\text{C}/^\circ\text{C}$	$\sim 0.23^\circ\text{C}$
User Defined*	0 to 1000 Ω	0 to 1000 Ω	$\pm 0.4 \Omega$	$\pm 0.009 \Omega/^\circ\text{C}$	$\sim 0.05 \Omega$

*The Callendar-Van Dusen linearization equation can be used with user defined Pt RTDs. Refer to Recommended I/O Practices in DeltaV Books online for usage information.

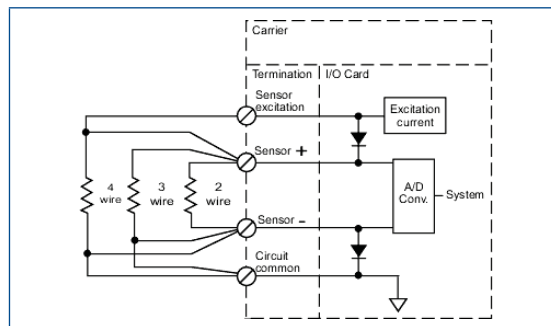

Simplified circuit diagram for RTD Input card, 8 channels.

Specifications for Thermocouple/mV Input Card, 8-channel	
Channels per Card	Eight
Sensor Types Thermocouple mV	B, E, J, K, N, R, S, T, uncharacterized Low level voltage source
Sensor Ranges	See table next page
Repeatability	0.05% of span
A/D Resolution	16-bit
Calibration	None required
Units	°C, °F
Cold Junction Compensation (Not available on mV channels)	Local: Integrally mounted in terminal block External: Configure one channel as external cold junction compensation for remaining inputs
Isolation	Each channel is optically isolated from the system and factory tested to 1500V DC. Channels 1, 2, 3, and 4 are isolated from channels 5, 6, 7, and 8 (verified by 1500V DC factory test). Thermocouples attached to channels 1, 2, 3, and 4 are not electrically isolated and should be within + 0.7V DC of each other. Thermocouples attached to channels 5, 6, 7, and 8 are not electrically isolated and should be within + 0.7V DC of each other.
Common Mode Rejection	120 dB at DC/50/60 Hz
Common Mode Impedance	> 10 mega ohms
Normal Mode Rejection	60 dB at 60 Hz
LocalBus Current (12V DC nominal)	210 mA
Open Sensor Detection	Yes (< 70 nA)
Open Sensor Detection Time	10 seconds

Thermocouple Sensor Type Specifications					
Sensor Type	Full Scale	Operating Range	25°C Reference Accuracy	Temperature Drift	Resolution
Uncharacterized (no linearization, no cold junction compensation.)	-100 to 100 mV	-100 to 100 mV	0.1 mV	± 0.002 mV/°C	~0.003mV
B	250 to 1810°C	500 to 1810°C	± 2.4°C	± 0.056°C/°C	~0.18°C
E	-200 to 1000°C	-200 to 1000°C	± 0.6°C	± 0.008°C/°C	~0.07°C
J	-210 to 1200°C	-190 to 1200°C	± 0.8°C	± 0.011°C/°C	~0.05°C
K	-270 to 1372°C	-200 to 1372°C	± 0.5°C	± 0.016°C/°C	~0.18°C
N	-270 to 1300°C	-190 to 1300°C	± 1.0°C	± 0.007°C/°C	~0.10°C
R	-50 to 1768°C	-50 to 1768°C	± 2.1°C	± 0.013°C/°C	~0.14°C
S	-50 to 1768°C	-40 to 1768°C	± 2.2°C	± 0.067°C/°C	~0.24°C
T	-270 to 400°C	-200 to 400°C	± 0.7°C	± 0.001°C/°C	~0.04°C

RTD, ohms Sensor Type Specifications					
Sensor Type	Full Scale	Operating Range	25°C Reference Accuracy	Temperature Drift	Resolution
Low-level Voltage Source	-100 to 100 mV	-100 to 100 mV	0.1 mV	0.002 mV/°C	~0.003 mV°

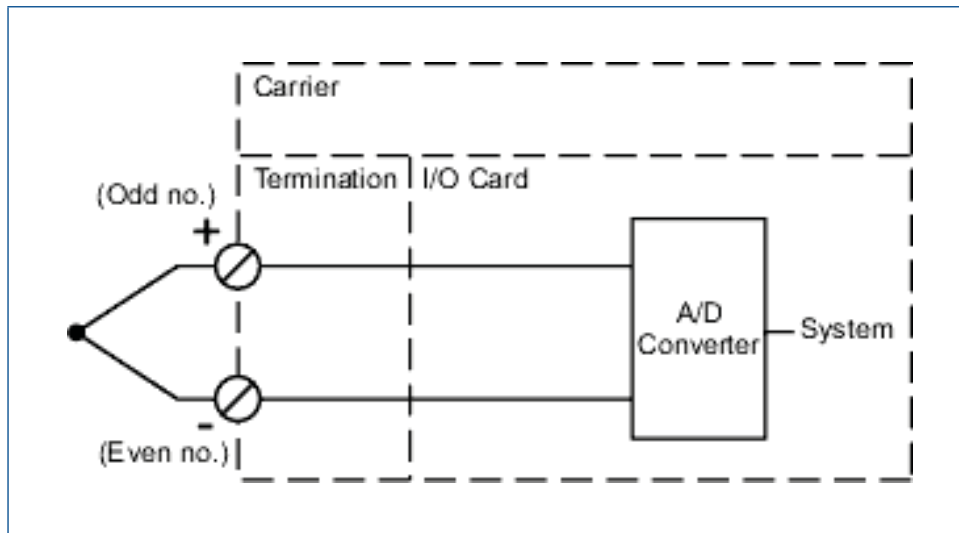

Simplified circuit diagram of Thermocouple/mV card, 8 channels.

Specifications for Isolated Input Card, 4-channel	
Number of Channels	4
Isolation CAN/CSA-C22.2 No.1010.1-92	Installation Cat II, Pollution degree 2 Channel-to-system - 600V AC double insulation. Each channel is optically isolated from the system and factory tested to 5000V DC. Channel-to-channel - 600V basic insulation. Each channel is optically isolated from each other and factory tested to 3100V DC.
Dielectric Strength	Channel-to-system - 3700V RMS Channel-to-channel - 2200V RMS
ADC Resolution	16-bit
-3dB Filter Frequency	2.7 Hz
DC/50/60 Hz Common Mode Rejection	120 dB
Input Impedance	10 Megaohms
Thermocouple Sensor Types	B, E, J, K, N, R, S, T, Uncharacterized
RTD Sensor Types	PT100, PT200, Ni120, Cu10, Resistance/User Defined
mV and V Ranges	Refer to following tables
Input Type Mix	Independently configurable
Ambient Temperature	-40° to 70°C
Calibration	None required
Mounting	Assigned slot of I/O carrier
LocalBus Power Rating	12V DC, 350 mA, no field power required

Isolated Input Card, Thermocouple, and MilliVolt Input Specifications

Item	Specification
Linearization Error	±0.003% full scale
Cold Junction Compensation Accuracy	±1.0°C
Cold Junction Compensation Types	Off, local, remote
Cold Junction Compensation Range	-40 to 85°C
Temperature Scale	ITS90
Open Circuit Detection (Thermocouple Only)	0.4 µA DC
Detection Time	1 second

Thermocouple Sensor Type Specifications					
Sensor Type	25°C Reference Accuracy	Temperature Drift	Nominal Resolution	Full Scale	Operating Range
B	±1.2°C	±0.116°C/°C	0.09°C	250 to 1810°C	500 to 1810°C
E	±0.5°C	±0.004°C/°C	0.05°C	-200 to 1000°C	-200 to 1000°C
J	±0.6°C	±0.005°C/°C	0.06°C	-210 to 1200°C	-190 to 1200°C
K	±0.5°C	±0.013°C/°C	0.05°C	-270 to 1372°C	-140 to 1372°C
N	±1.0°C	±0.015°C/°C	0.05°C	-270 to 1300°C	-190 to 1300°C
R	±1.7°C	±0.083°C/°C	0.06°C	-50 to 1768°C	0 to 1768°C
S	±1.8°C	±0.095°C/°C	0.08°C	-50 to 1768°C	0 to 1768°C
T	±0.7°C	±0.025°C/°C	0.04°C	-270 to 400°C	-200 to 400°C
Uncharacterized no linearization or CJC	±0.05 mV	±0.0003 mV/°C	0.0031 mV	-100 to 100 mV	-100 to 100 mV

Isolated Input Millivolt Input Range Specifications				
Sensor Type	Input Ranges	25°C Reference Accuracy	Temperature Drift	Maximum Resolution
20 mV Source	±20 mV	±0.02 mV	±0.001 mV/°C	0.0008 mV
50 mV Source	±50 mV	±0.03 mV	±0.0005 mV/°C	0.0017 mV
100mV Source	±100 mV	±0.05 mV	±0.0003 mV/°C	0.0031 mV

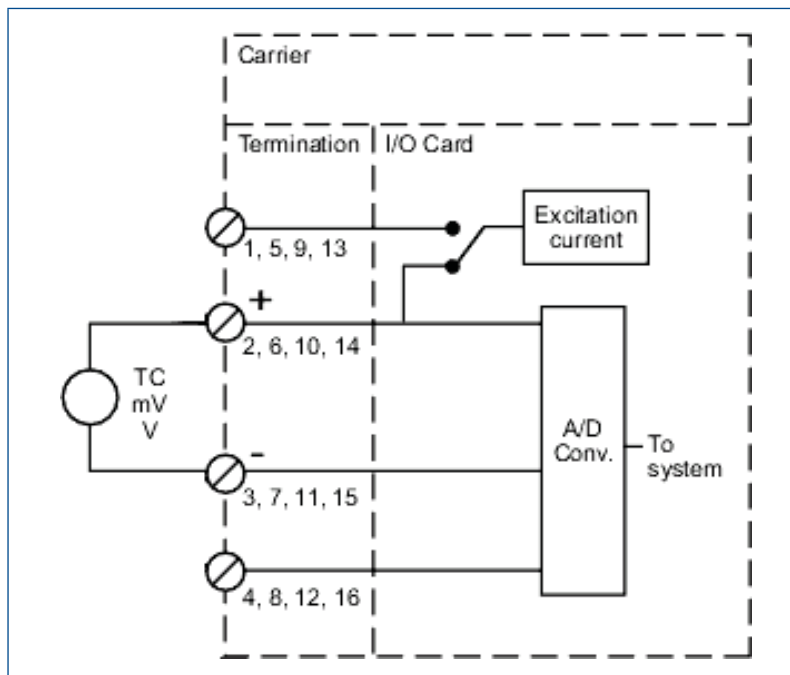

Simplified circuit diagram of Isolated Input card, Thermocouple, mV, V, 4 channels.

Isolated Input Card, RTD, ohms Input Specifications

Item	Specification
Measurement Configurations	2, 3, and 4 wire
Excitation Current	100 μ A DC
Temperature Scale	ITS90
Open Sensor Detection Time	1 second
Short Circuit Detection Time	1 second
Pt 100 and Pt 200 Alpha	0.00385
Detection Time	1 second

Isolated Input Card, RTD, ohms Input Specifications

Sensor Type	25°C Reference Accuracy	Temperature Drift	Resolution	Sensor Input Range
Pt100	$\pm 0.5^\circ\text{C}$	$\pm 0.018^\circ\text{C}/^\circ\text{C}$	0.05°C	-200 to 850°C
Pt200	$\pm 0.5^\circ\text{C}$	$\pm 0.012^\circ\text{C}/^\circ\text{C}$	0.05°C	-200 to 850°C
Ni120	$\pm 0.2^\circ\text{C}$	$\pm 0.006^\circ\text{C}/^\circ\text{C}$	0.02°C	-70 to 300°C
Cu10	$\pm 2.0^\circ\text{C}$	$\pm 0.076^\circ\text{C}/^\circ\text{C}$	0.23°C	-30 to 140°C
Resistance	± 0.5 ohms	± 0.018 ohms/ $^\circ\text{C}$	0.02 ohms	1 to 1000 ohms
User Defined*	± 0.4 ohms	± 0.009 ohms/ $^\circ\text{C}$	~ 0.05 ohms	0 to 1000 ohms

*The Callendar-Van Dusen linearization equation can be used with user defined Pt RTDs. Refer to Recommended I/O Practices in DeltaV Books online for usage information.

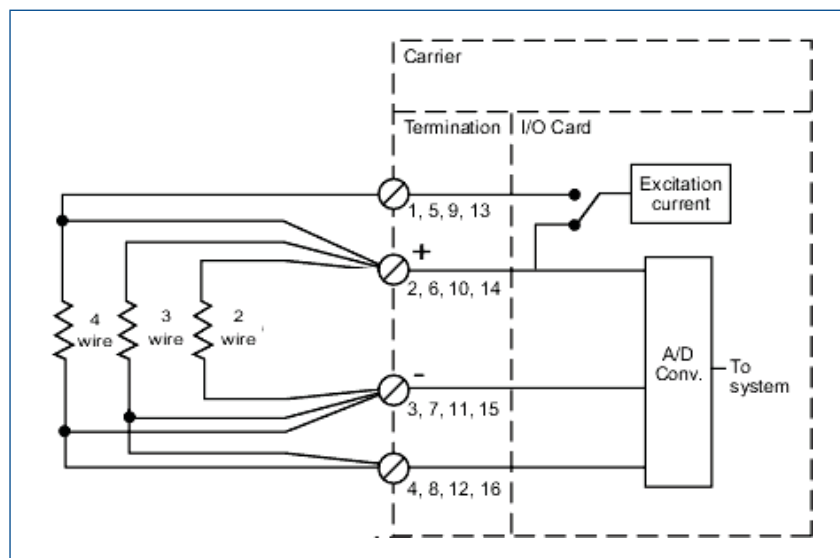

Simplified circuit diagram of Isolated Input card, RTD, 4 channels.

Isolated Input Card, Voltage Input Range Specifications

Sensor Type	Sensor Range	25°C Reference Accuracy	Temperature Drift	Maximum Resolution
0 - 5V	0 - 5V	±0.005V	±0.0002V/°C	0.00009V
0 - 10V	0 - 10V	± 0.010V	±0.0004V/°C	0.00016V
1 - 5V	1 - 5V	±0.0005V	±0.0002V/°C	0.00009V
1V	+/- 1V	±0.0025V	±0.0002V/°C	0.00015V
5V	+/- 5V	±0.005V	±0.0002V/°C	0.00017V
10V	+/- 10V	±0.010V	±0.0004V/°C	0.0003V

Analog Output I/O Cards

Item	Specification
Number of Channels	Eight
Isolation	Each channel is optically isolated from the system and factory tested to 1500V DC.
Nominal Signal Range (span)	4 to 20 mA
Full Signal Range	1 to 23 mA
LocalBus Current (12V DC nominal) per Card	100 mA typical, 150 mA maximum
Field Circuit Power per Card	300 mA maximum @ 24V DC (+/-10%)
Accuracy Over Temperature Range	0.25% of span
Resolution	12-bit
Output Compliance	20 mA at 21.6V DC supply into 700 ohms load
Calibration	Information stored on card.
Optional Fuse	2.0 A

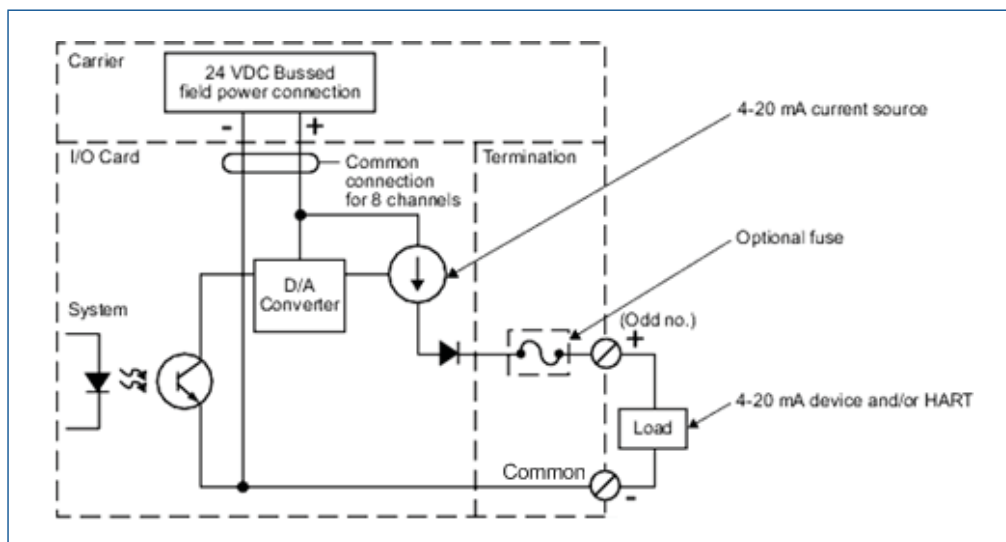

Simplified circuit and connection diagram for simplex AO card, 8-channel, 4 to 20 mA, HART.

Specifications for AO (Plus) Card, 16-Channel, 4 to 20 mA, HART	
Number of Channels	16
Device Types	4 to 20 mA
Full Signal Range	1 to 23 mA
Accuracy Over Temperature Range	0.25% of span
Resolution	14-bit A/D converter
Calibration	None required
Local Bus Current per Card (12V DC nominal)	Simplex: 85 mA typical, 150 mA maximum. Redundant: 110 mA typical, 260 mA maximum.
Field Circuit Power per Card	400 mA maximum @ 24V DC (+/-10%)
Isolation	Each channel is optically isolated from the system and factory tested to 1000V DC.
HART Communications Support	HART pass-through for AMS Device Manager. HART variable and status reporting for control functions.
Hart Scan Time	600 – 800 mS (typical) per enabled channel

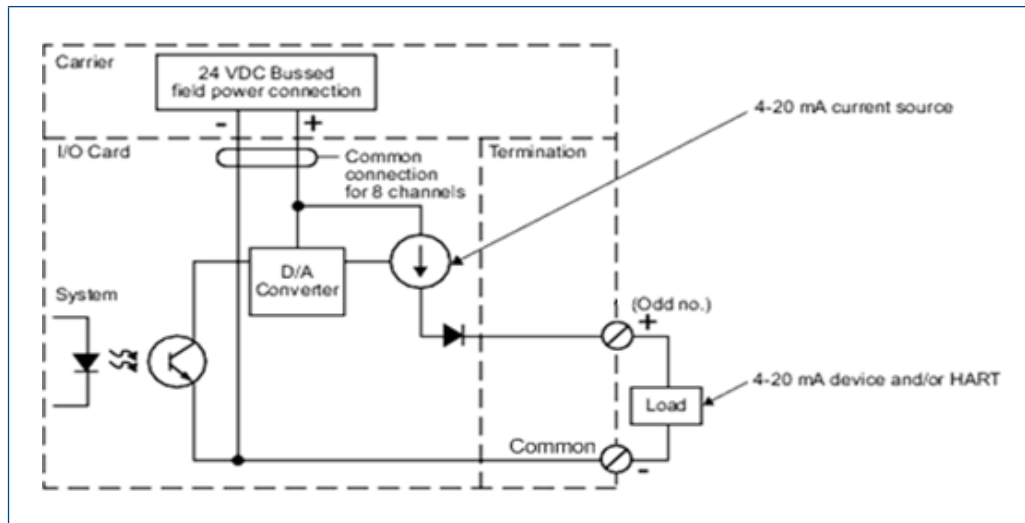

Simplified circuit and connection diagram for simplex AO (Plus) card, 16-channel, 4 to 20 mA, HART.

Discrete Input I/O Cards

Specifications for DI Card, 8-channel, 24V DC, Dry Contact	
Number of Channels	Eight
Input Compatibility	Dry Contact (known to operate with many NAMUR sensors)
Detection Level for On	>2.2 mA
Detection Level for Off	<1 mA
Input Impedance	5 K Ω (approximate)
Wetting Voltage	15 Volts
Fault Detection Capable	Field resistor pack (known to operate with many NAMUR sensors)
Configurable Channel Types:	Input
<ul style="list-style-type: none"> ■ Discrete Input ■ Pulse Count 	Dry contact or discrete state sensor changing <2 Hz. Pulse train <75 Hz
Local Bus current (12V DC nominal) per Card	Simplex: 75 mA typical, 100 mA maximum Redundant: 90 mA typical, 150 mA maximum
Field Circuit Power per Card	100 mA at 24V DC ($\pm 10\%$)
Isolation	Each channel is optically isolated from the system and factory tested to 1500V DC.
Optional Fuse	2.0 A (Terminal block option)

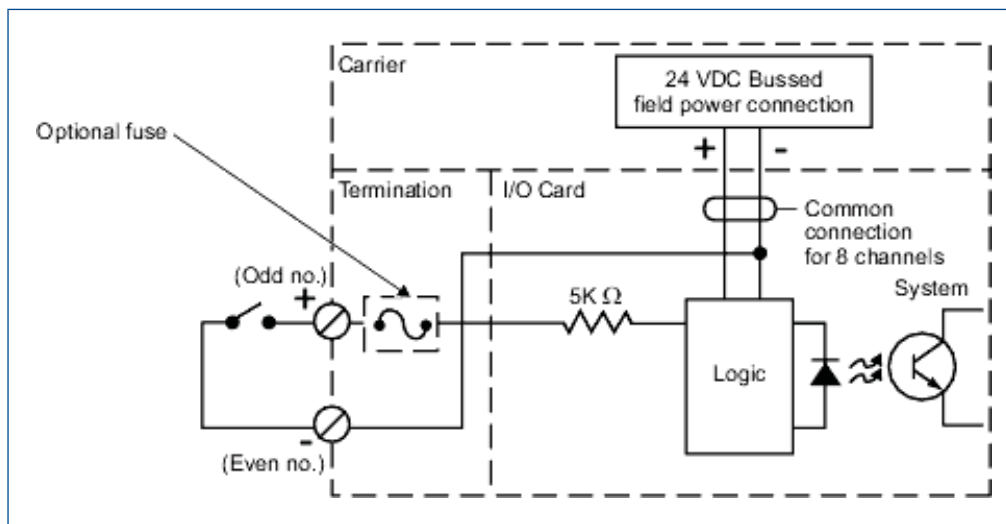

Simplified circuit and connection diagram for DI card, 8-channel, 24V DC, Dry Contact.

Specifications for DI Card, 8-channel, 24V DC, Isolated	
Number of Channels	Eight
Isolation	Each channel is optically isolated from the system and from each other and factory tested to 1500V DC.
Detection Level for On	>10V DC
Detection Level for Off	<5V DC
Input Impedance	5 mA at 24V
LocalBus Current (12V DC nominal) per Card	75 mA typical, 100 mA maximum
Field Circuit Power per Card	None
Optional Fuse	2.0 A

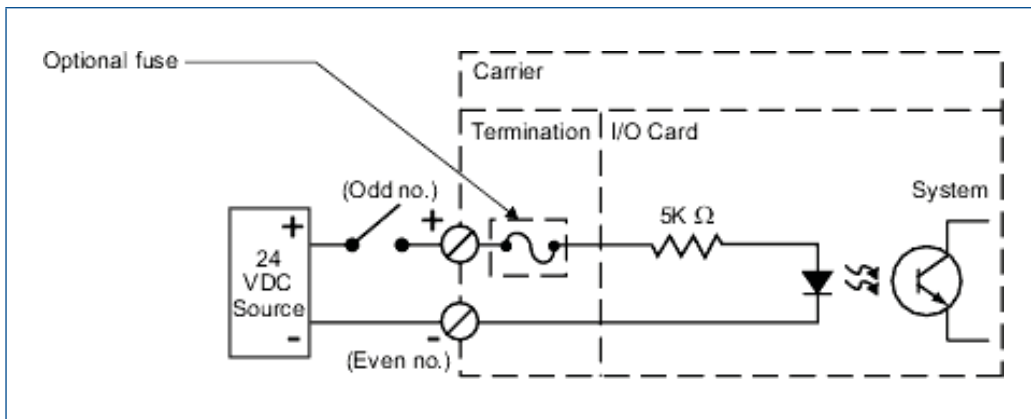

Simplified circuit and connection diagram for DI card, 8-channel, 24V DC, Isolated.

Specifications for DI Card, 32-channel, 24V DC, Dry Contact	
Number of Channels	32
Isolation	Each channel is optically isolated from the system and factory tested to 1500V DC.
Detection Level for On	>2 mA
Detection Level for Off	<0.25 mA
Input Impedance	5K ohm (approximate)
LocalBus Current (12V DC nominal) per Card	50 mA typical, 75 mA maximum
Field Circuit Power per Card	150 mA at 24V DC
Return	Uses common return
Terminal Block	32-screw termination block
Specifications for DI (Plus) Card, 32-channel, 24V DC, Dry Contact	
Number of Channels	32
Detection Level for On	>2 mA
Detection Level for Off	<0.25 mA
Input Impedance	5K ohm (approximate)
Wetting Voltage	24V DC
Local Bus Current (12V DC Nominal)	50 mA typical, 75 mA maximum
Field Circuit Power per Card	150 mA maximum @ 24V DC (+20%/-15%)
Isolation	Each channel is optically isolated from the system and factory tested to 1500V DC.

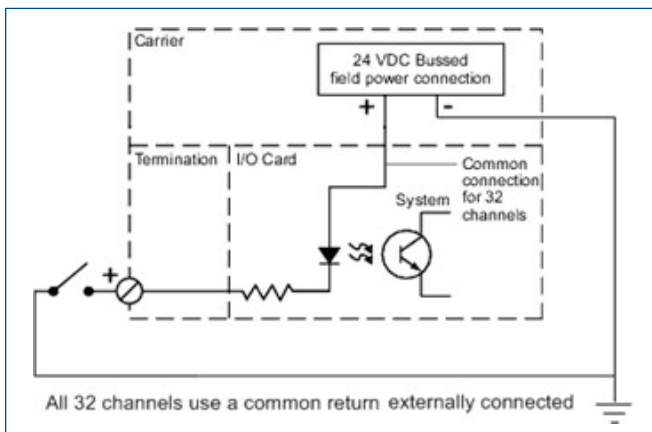

Simplified circuit and connection diagram for DI Card, 32-channel, 24V DC, Dry contact.

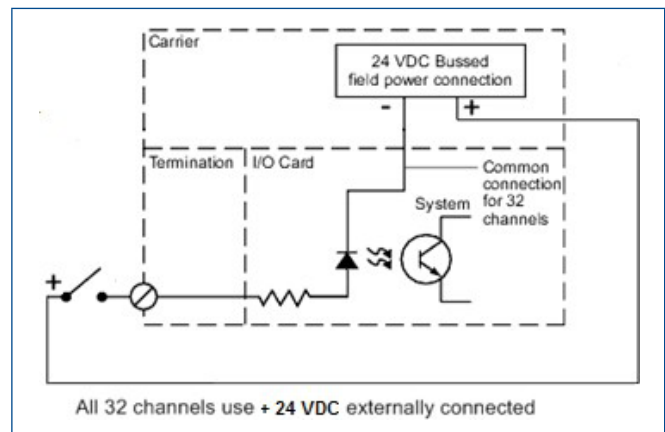

Simplified circuit and connection diagram for simplex DI Plus Card, 32-channel, 24V DC, Dry contact.

Specifications for DI Card, 8-channel, 120V AC, Dry Contact	
Number of Channels	Eight
Isolation	Each channel is optically isolated from the system at 250V AC
Detection Level for On	>1.4 mA
Detection Level for Off	<0.56 mA
Input Impedance	60 KΩ
LocalBus Current (12V DC nominal) per Card	75 mA typical, 100 mA maximum
Field Circuit Power per Card	15 mA at 120V AC
Optional Fuse	2.0 A

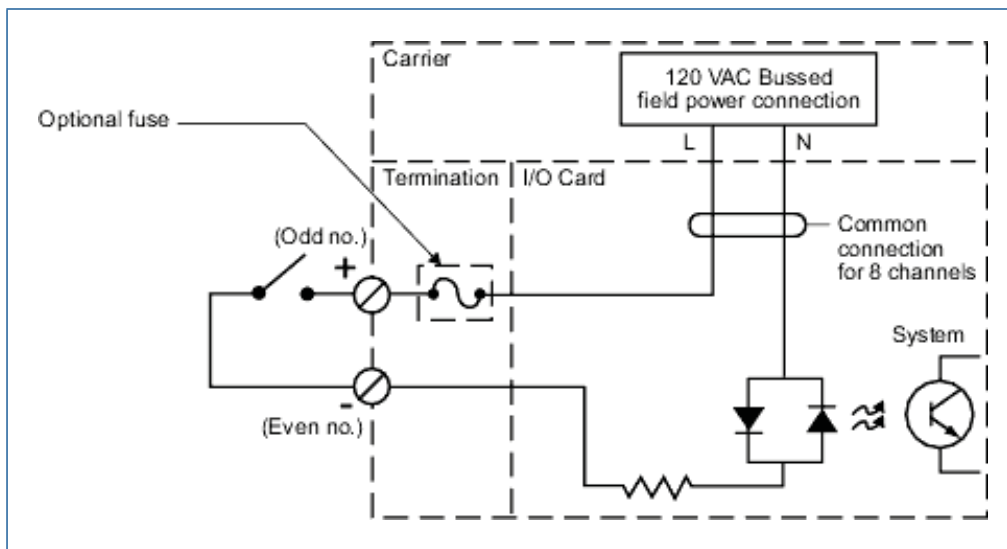

Simplified circuit and connection diagram for DI card, 8-channel, 120V AC, Dry Contact.

Specifications for DI Card, 8-channel, 120V AC, Isolated	
Number of Channels	Eight
Isolation	Each channel is optically isolated from the system at 250V AC and from other channels at 250V AC.
Detection Level for On	84 to 130V AC
Detection Level for Off	0 to 34V AC
Input Load (contact cleaning)	2 mA at 120V AC
Input Impedance	60 KΩ
LocalBus Current (12V DC nominal) per Card	75 mA typical, 100 mA maximum
Field Circuit Power per Card	None
Optional Fuse	2.0 A

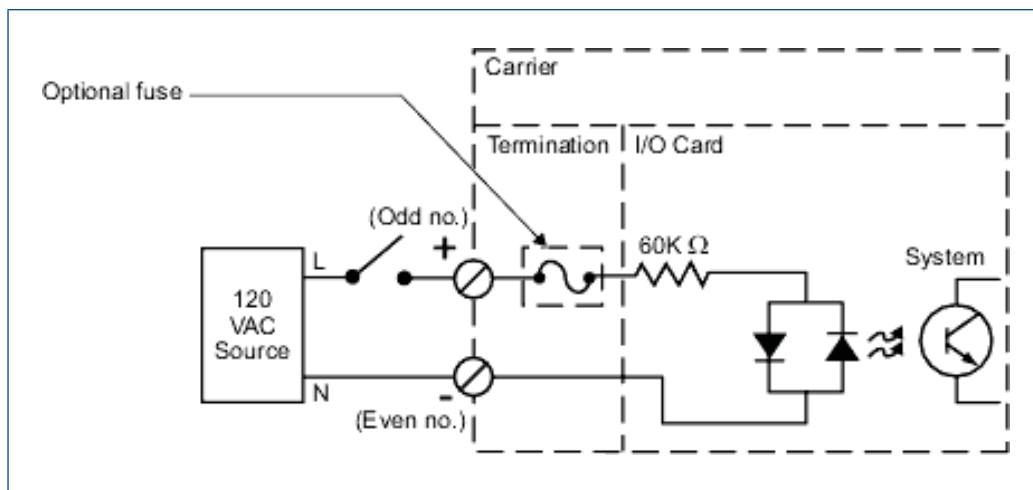

Simplified circuit and connection diagram for DI card, 8-channel, 120V AC, Isolated.

Specifications for PCI Card, 4-channel, 24V DC, Dry Contact	
Number of Channels	Four
Detection Level for ON (min.)	>4.8V DC (>5 mA)
Detection Level for OFF (max.)	<1.0V DC (<1 mA)
Input Impedance	25 mA at 24V DC (960 Ohms)
Input Accuracy	0.1% reading (over 0.1 Hz to 50 kHz)
Resolution	+/- 1 pulse
Minimum Pulse Width	10 μ S
Maximum Input Voltage	24V DC +20%
Resolution Counter	32-bit
Input Frequency	Sine wave 10 Hz to 50kHz Square wave 0.1 Hz to 50 kHz
Wetting Voltage	24V DC
LocalBus Current (12V DC nominal)	150 mA maximum
Field Circuit Power per Card	25 mA at 24V DC (1 A resettable fuse)
Isolation	Each channel is optically isolated from the system at 250V AC and from other channels at 100V AC.

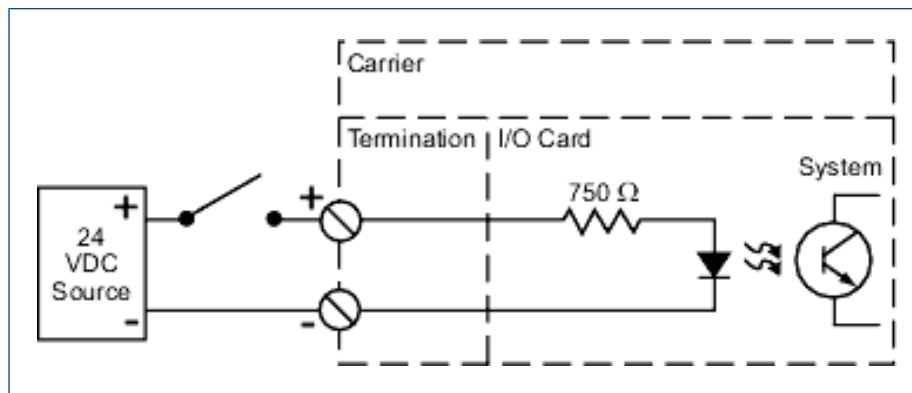

Simplified circuit and connection diagram for PCI card, 4 channel, 24V DC, Isolated.

Specifications for SOE Card, 16-channel, 24V DC, Dry Contact	
Number of Channels	16
Detection Level for On	>2 mA
Detection Level for Off	<0.25 mA
Input Impedance	5K ohm (approximate)
Wetting Voltage	24V DC
Channel Scan Rate	0.25 msec for all 16 channels
Time Stamp Accuracy (for SOE enabled channels only)*	0.25 msec from same card 1 msec from same controller
LocalBus Current (12V DC nominal)	75 mA typical, 100 mA maximum
Field Circuit Power per Card	75 mA at 24V DC
Isolation	Each channel is optically isolated from the system and factory tested to 1500V DC.

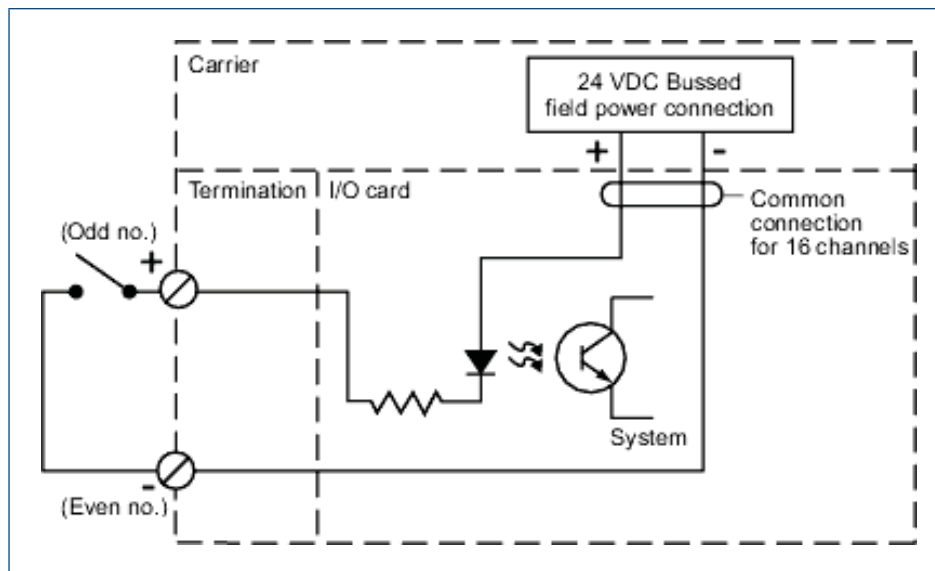

Simplified circuit and connection diagram for SOE card, 16-channel, 24V DC, Dry contact.

*Refer to Sequence of Event Product Data Sheet for more information on System capabilities and Sequence of Event data collection.

Discrete Output I/O Cards

Specifications for DO Card, 8-channel, 24V DC, Isolated	
Number of Channels	Eight
Isolation	Each channel is optically isolated from the system and from each other and factory tested to 1500V DC.
Output Range	2V DC to 60V DC
Output Rating	1.0 A
Off State Leakage	1.2 mA maximum
LocalBus Current (12V DC nominal) per Card	100 mA typical, 150 mA maximum
Field Circuit Power per Card	None
Configurable Channel Types	Output
Discrete Output	Output stays in last state submitted by the controller.
Momentary Output	Output is active for a pre-configured time period (100 ms to 100 s).
Continuous Pulse Output	Output is active as a percentage of a pre-configured base time period (100 ms to 100 s). Resolution = 5 ms

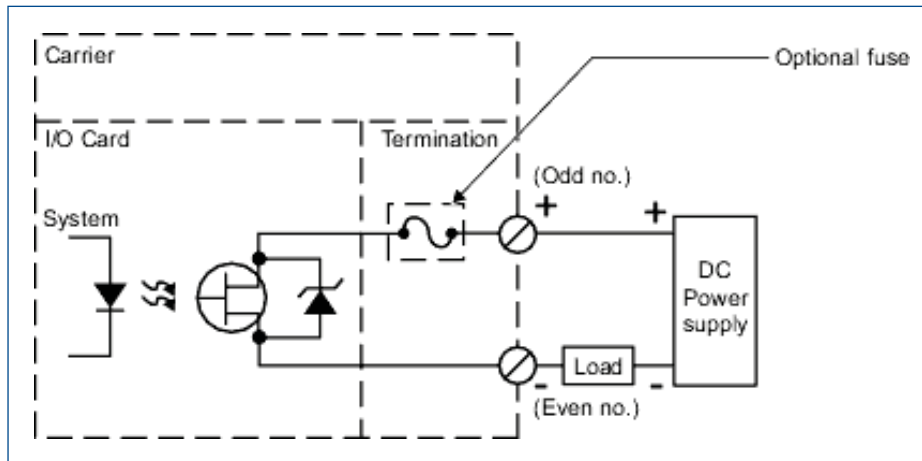

Simplified circuit and connection diagram for DO card, 8-channel, 24V DC, Isolated.

Specifications for DO Card, 8-channel, 24V DC, High-Side	
Number of Channels	Eight
Isolation	Each channel is optically isolated from the system and factory tested to 1500V DC.
Output Range	2V DC to 60V DC
Output Rating	1.0 A continuous per channel; 3.0 A maximum per I/O Interface
Off State Leakage	1.2 mA maximum
LocalBus Current (12V DC nominal) per Card	100 mA typical, 150 mA maximum
Field Circuit Power per Card	3.0 A at 24V DC per I/O Interface
Configurable Channel Types	Output
Discrete Output	Output stays in last state submitted by the controller.
Momentary Output	Output is active for a pre-configured time period (100 ms to 100 s).
Continuous Pulse Output	Output is active as a percentage of a pre-configured base time period (100 ms to 100 s). Resolution = 5 ms
Optional Fuse	2.0 A

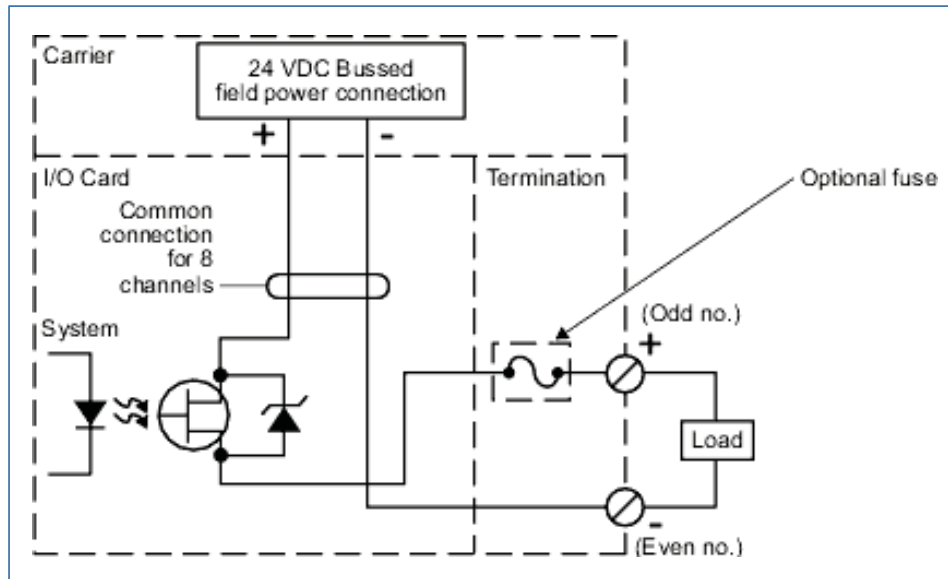

Simplified circuit and connection diagram for DO card, 8-channel, 24V DC, High-Side.

Specifications for DO (plus) Card, 32-channel, 24V DC, High-Side	
Number of Channels	32
Output Rating	100 mA per channel
Output Range	24V DC \pm 10%
Off-State Leakage	0.1 mA maximum
Local Bus Current (12V DC Nominal)	100 mA typical, 150 mA maximum
Field Circuit Power per Card	3.2 A @ 24V DC (+20%/-15%)
Isolation	Each channel is optically isolated from the system and factory tested to 1500V DC.

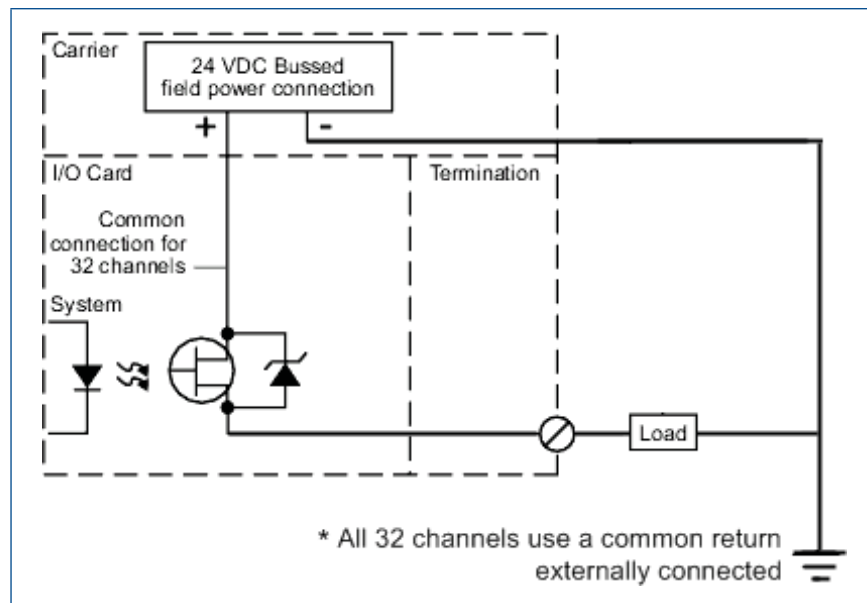

Simplified circuit and connection diagram for simplex DO (Plus) Card, 32-channel, 24V DC, High-Side.

Specifications for DO Card, 8-channel, 120/230V AC, Isolated	
Number of Channels	Eight
Isolation	Each channel is optically isolated from system at 250V AC and from other channels at 250V AC
Output Range	20 to 250V AC
Output Rating	1.0 A continuous per channel; 2.0 A maximum per card up to 60°C (140°F) 3.0 A maximum per card up to 50°C (122°F)
Off State Leakage	2 mA maximum at 120V AC 4 mA maximum at 230V AC
LocalBus Current (12V DC nominal) per Card	100 mA typical, 150 mA maximum
Field Circuit Power per Card	None
Configurable Channel Types	Output
Discrete Output	Output stays in last state submitted by the controller.
Momentary Output	Output is active for a pre-configured time period (100 ms to 100 s).
Continuous Pulse Output	Output is active as a percentage of a pre-configured base time period (100 ms to 100 s). Resolution = 5 ms
Optional Fuse	2.0 A

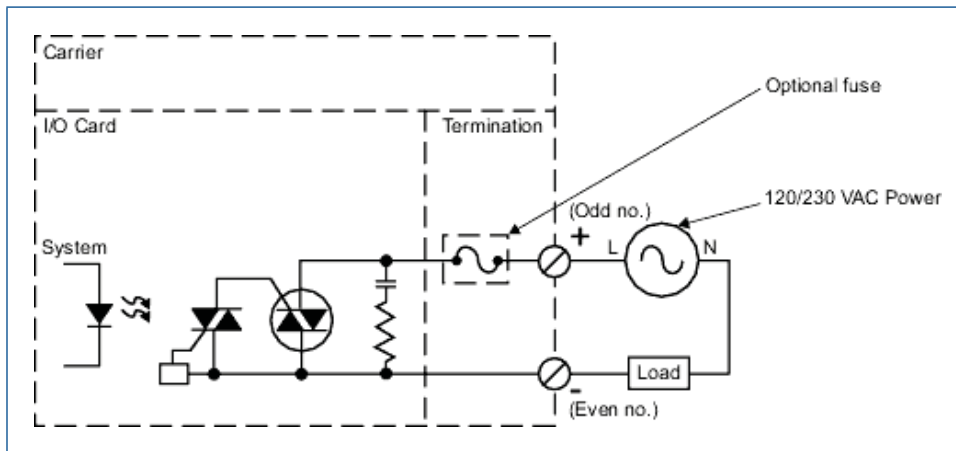

Simplified circuit and connection diagram for DO card, 8-channel, 120/230V AC, Isolated.

Specifications for DO Card, 8-channel, 120/230V AC, High-Side	
Number of Channels	Eight
Isolation	Each channel is optically isolated from the system at 250V AC
Output Range	20 to 250V AC
Output Rating	1.0 A continuous per channel 2.0 A maximum per card up to 60°C (140°F) 3.0 A maximum per card up to 50°C (122°F)
Off State Leakage	2 mA maximum at 120V AC 4 mA maximum at 230V AC
LocalBus Current (12V DC nominal) per Card	100 mA typical, 150 mA maximum
Field Circuit Power per Card	3.0 A at 120V AC or 230V AC
Configurable Channel Types	Output
Discrete Output	Output stays in last state submitted by the controller
Momentary Output	Output is active for a pre-configured time period (100 ms to 100 s).
Continuous Pulse Output	Output is active as a percentage of a pre-configured base time period (100 ms to 100 s). Resolution = 5 ms
Optional Fuse	2.0 A

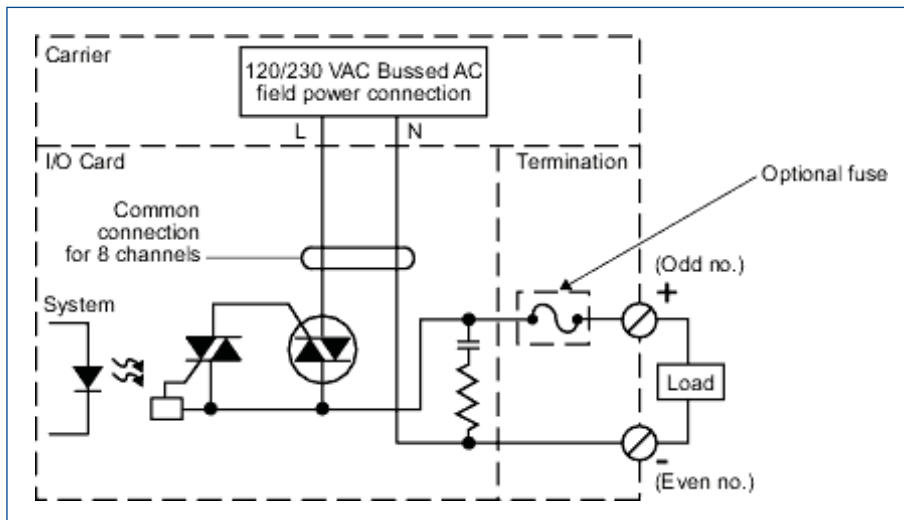

Simplified circuit and connection diagram for DO card, 8-channel, 120/230V AC, High-Side.

I/O Terminal Blocks

A variety of I/O terminal blocks are available to meet specific functionality and environmental requirements of the installation. The I/O interface is a combination of the I/O card and the I/O terminal block. Each I/O interface is uniquely keyed so that once installed in a carrier slot with a terminal block, that terminal block will only accept a replacement card.



8-channel standard terminal block.

The keying mechanism consists of two keying posts that rotate and lock into the terminal block base. Each post has 6 positions: A-F and 1-6. Each card is assigned a unique key, which is marked on the side of the I/O card:

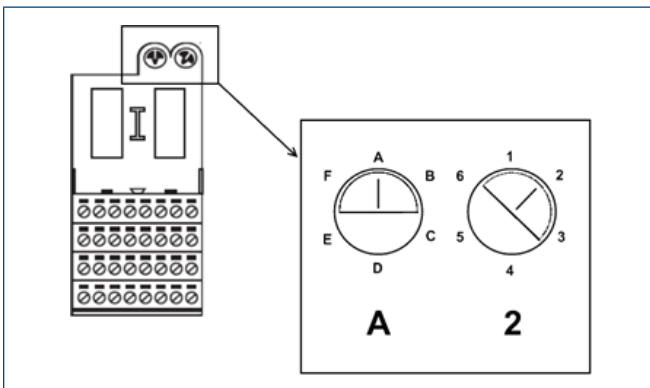

Terminal block keying example.

The keys prevent installation of an incorrect card, and the graphical information on the card makes it easy to determine if a keyed slot will accept a particular card.

There are different I/O terminal blocks available to meet the wiring needs of field signals.

- 8-Channel terminal block
- Fused 8-Channel terminal block
- AI 8-Channel terminal block
- 2-wire AI Plus 16-Channel terminal block
- 4-wire AI Plus 16-Channel terminal block
- AO Plus 16-Channel terminal block
- DI 32-Channel terminal block
- DI Plus 32-Channel terminal block
- DO Plus 32-Channel terminal block
- Isolated Input terminal block
- RTD/Resistance terminal block
- Thermocouple terminal block

The following redundant I/O terminal blocks are available on some I/O interfaces, allowing a pair of cards to be installed as a redundant pair.

- Redundant AI 8-Channel terminal block
- Redundant AI Plus 16-Channel terminal block
- Redundant AO 8-Channel terminal block
- Redundant AO Plus 16-Channel terminal block
- Redundant Discrete 8-Channel terminal block
- Redundant DI Plus 32-Channel terminal block
- Redundant DO Plus 32-Channel terminal block

The table on the following page lists the compatible terminal blocks for each card, along with the cards unique key positions. The first terminal block listed is the recommended terminal block.

In addition to standard signal wiring, some cards may also be ordered with Mass Terminal blocks that allow these cards to be connected to the M-series Mass Connection Solutions or third party wiring solutions from Phoenix or if IS Barriers are required from Pepperl and Fuchs, mounted in an adjacent cabinet to meet special signal conditioning or for optimizing field wiring solutions. Please refer to the Alliance Program website for details on approved third-party products.

- 10-pin Mass Termination Block (simplex only)
- 16-pin Mass Termination Block (simplex only)
- 24-pin Mass Termination Block (simplex only)
- 40-pin Mass Termination Block (simplex and redundant)
- 48-pin Mass Termination Block (simplex and redundant)

Traditional I/O and Terminal Block Compatibility

I/O Card	I/O Card Keying	Traditional I/O Terminal Blocks	Mass Termination Blocks
AI, 8-Channel, 4–20 mA, HART	A1	I/O terminal block Fused I/O terminal block 4-wire I/O terminal block	16-pin Mass termination block (Supports 2-wire Devices) 24-pin Mass termination block (Supports 4-wire Devices)
AI Plus, 16-Channel, 4-20 mA, HART	A6	16-Channel 2-Wire AI terminal block for Series 2 Plus 16-Channel 4-Wire AI terminal block for Series 2 Plus Redundant 2- & 4-Wire terminal block	48-pin AI Mass termination block for Series 2 Plus Redundant 48-pin AI Mass termination block for Series 2 Plus
AO, 8-Channel, 4–20 mA, HART	A4	I/O terminal block Fused terminal block	16-pin Mass termination block
AO Plus, 16-Channel, 4-20 mA, HART	A5	16-Channel AO terminal block for Series 2 Plus Redundant 16-Channel AO terminal block for Series 2 Plus	48-pin AO Mass termination block for Series 2 Plus Redundant 48-pin AO Mass termination block for Series 2 Plus
Thermocouple, mV	C1	I/O terminal block Cold Junction Compensated (CJC) terminal block	NA
RTD, 8-Channel	C3	Resistant Temperature Device (RTD) terminal block	NA
Isolated Input Card	C2	Isolated Input terminal block	NA
DI, 8-Channel, 24V DC, Dry Contact	B1	I/O terminal block Fused terminal block	16-pin Mass termination block
DI, 8-Channel, 24V DC, Isolated	B2	I/O terminal block Fused terminal block	16-pin Mass termination block
DI, 32-Channel, 24V DC, Dry Contact	B3	32-Channel terminal block	40-pin Mass termination block
DI Plus, 32-Channel, 24V DC, Dry Contact	E3	32-Channel DI terminal block for Series 2 Plus Redundant 32-Channel DI terminal block for Series 2 Plus	40-pin DI Mass termination block for Series 2 Plus Redundant 40-pin DI Mass termination block for Series 2 Plus
PCI, 4-Channel	C6	32-Channel terminal block	NA
SOE, 16-Channel, 24V DC	C5	32-Channel terminal block	40-pin Mass termination block
DO, 8-Channel, 24V DC, High-Side	B6	I/O terminal block Fused terminal block	10-pin Mass termination block 16-pin Mass termination block

I/O Card	I/O Card Keying	Traditional I/O Terminal Blocks	Mass Termination Blocks
DO, 8-Channel, 24V DC, Isolated	B5	I/O terminal block Fused terminal block	16-pin Mass termination block
DO Plus, 32-Channel, 24V DC High-Side	B4	32-Channel DO terminal block for Series 2 Plus Redundant 32-Channel DO terminal block for Series 2 Plus	40-pin DO Mass termination block for Series 2 Plus Redundant 40-pin DO Mass termination block for Series 2 Plus
DI, 8-Channel, 120V AC, Dry Contact	E1	I/O terminal block Fused terminal block	NA
DI, 8-Channel, 120V AC, Isolated	E4	I/O terminal block Fused terminal block	NA
DO, 8-Channel, 120V AC/ 230V AC, High-Side	F1	I/O terminal block Fused terminal block	NA
DO, 8-Channel, 120V AC/ 230V AC, Isolated	F4	I/O terminal block Fused terminal block	NA

System Compatibility

M-series traditional I/O hardware requires:

- MQ, MX or PK controllers.
- M-series horizontal or VerticalPlus carriers.

S-series and M-series controllers can be installed on the same DeltaV Area Control Network in v11.3.1 and beyond. Control modules can be assigned to any controller and inter-controller references are fully supported.

The following traditional I/O Plus cards require v13.3.1 or higher Software:

- AI Plus, 4-20 mA HART, 16 Channels.
- AO Plus, 4-20 mA HART, 16 Channels.
- DI Plus, 32-channel, 24V DC Dry contact.
- DO Plus, 32-channel, 24V DC High-Side.

Termination Fault Detection is a feature that only works within the following cards:

- DI Plus, 32-channel, 24V DC Dry contact.
- DO Plus, 32-channel, 24V DC High-Side.

when used with the redundant 40-pin Mass DI or DO Terminal Block combined with the M-series Mass Connection Solutions or P+F HiC IS barriers and termination boards for DeltaV DCS.

All other approved third party mass termination products may be used with both non Plus S-series and M-series I/O interfaces.

M-series traditional I/O horizontal carriers are not physically compatible with S-series horizontal controller carriers. Install M-series I/O interfaces with M-series controllers and S-series I/O interfaces with S-series controllers.

Certifications

The following certifications are available for M-series Traditional I/O (see actual certificates for exact certifications for each product):

- **CE**
EMC: EN 61326-1
- **FM**
FM 3600
FM 3611
- **CSA**
CSA C22.2 No. 213
CSA C22.2 No. 1010-1
- **ATEX**
EN60079-0
IEC60079-7
EN60079-15
- **IEC-Ex**
IEC60079-0
IEC60079-7
IEC60079-15
- **Marine Certifications: IACS E10**
ABS Certificate of Design Assessment
DNV Marine Certificate

Hazardous Area/Location

M-series Traditional I/O Cards can be installed and used based on the following standards (see actual certificates for exact product markings for each product):

- **FM (USA)**
Class I, Division 2, Groups A, B, C, D, T4
- **cFM (Canada)**
Class I, Division 2, Groups A, B, C, D, T4
- **ATEX**
II 3G Ex ec IIC T4 Gc
II 3G Ex ec [ic] IIC T4 Gc
II 3G Ex nA nC IIC T4 Gc
- **IEC-Ex**
II 3G Ex ec IIC T4 Gc
II 3G Ex ec ic IIC T4 Gc
II 3G Ex nA nC IIC T4 Gc

*Regarding the Installation instructions please refer to the following Documents:
Class 1 Division 2 Installation Instructions DeltaV M-series 12P1293
Zone 2 Installation Instructions DeltaV M-series 12P2046*

Ordering Information

Analog Input Cards and Termination Blocks	
Description	Model Number
8 Channels 4-20 mA, HART	
Standard I/O Termination Block	VE4003S2B1 **
Redundant Standard I/O Termination Block	VE4033S2B1 **
Fused I/O Termination Block	VE4003S2B2 **
4-wire I/O Termination Block	VE4003S2B3 **
16-Pin Mass Termination Block	VE4003S2B4 **
24-Pin Mass Termination Block	VE4003S2B5 **
16 Channels 4-20 ma, HART, Plus Card	
16-Channel 2-Wire AI Terminal Block for Series 2 Plus	VE4003S2B9
16-Channel 4-Wire AI Terminal Block for Series 2 Plus	VE4003S2B10
Redundant 16-Channel 2- & 4-Wire AI Terminal Block for Series 2 Plus	VE4033S2B10
48-pin AI Mass Termination Block for Series 2 Plus (to be used with DeltaV Signal Conditioning Cards for PLC-5 AI, or P+F HiC IS barriers and terminal boards for DeltaV DCS)	VE4003S2B11
48-pin AI Mass Termination Block for Series 2 Plus including 16-channel Analog Mass Connection Boards*	VE4053S2B11
Redundant 48-pin AI Mass Termination Block for Series 2 Plus (to be used with DeltaV Signal Conditioning Cards for PLC-5 AI, or P+F HiC IS barriers and terminal boards for DeltaV DCS)	VE4033S2B11
Redundant 48-pin AI Mass Termination Block for Series 2 Plus including 16-channel Analog Mass Connection Boards*	VE4083S2B11
8 Channels Thermocouple, mV	
Standard I/O Termination Block	VE4003S4B1
Cold Junction Compensated (CJC) Termination Block	VE4003S5B1
Analog Input Card: 8 Channels RTD	
Resistant Temperature Device (RTD) Termination Block	VE4003S6B1
Isolated Input Card	
Isolated Input Terminal Block	VE4003S7B1

*For more details on the Mass Connection Boards and connection cables, please refer to the M-series Mass Connection Solutions PDS.

**Supported on DeltaV v10.3.1 and later. DNV Marine Certification pending. If DNV certification is required or card will be used on earlier DeltaV versions, please request KJ3222X1-BA2.

Analog Output Cards and Termination Blocks	
Description	Model Number
8 Channels 4-20 mA, HART	
Standard I/O Termination Block	VE4005S2B1**
Redundant Standard I/O Termination Block	VE4035S2B1**
Fused I/O Termination Block	VE4005S2B2**
16-Pin Mass Termination Block	VE4005S2B3**
16 Channels 4-20 mA, HART, Plus Card	
16-Channel AO Terminal Block for Series 2 Plus	VE4005S2B4
Redundant 16-Channel AO Terminal Block for Series 2 Plus	VE4035S2B4
48-pin AO Mass Termination Block for Series 2 Plus (to be used with P+F HiC IS barriers and termination boards for DeltaV DCS)	VE4005S2B5
48-pin AO Mass Termination Block for Series 2 Plus including 16-channel Analog Mass Connection Boards*	VE4055S2B5
Redundant 48-pin AO Mass Termination Block for Series 2 Plus (to be used with P+F HiC IS barriers and termination boards for DeltaV DCS)	VE4035S2B5
Redundant 48-pin AO Mass Termination Block for Series 2 Plus including 16-channel Analog Mass Connection Boards*	VE4085S2B5

*For more details on the Mass Connection Boards and connection cables, please refer to the M-series Mass Connection Solutions PDS.

**Supported on DeltaV v10.3.1 and later. DNV Marine Certification pending. If DNV certification is required or card will be used on earlier DeltaV versions, please request KJ3221X1-BA2.

Discrete Input Cards and Termination Blocks	
Description	Model Number
Discrete Input Card: 8 Channels, 24V DC, Isolated	
Standard I/O Termination Block	VE4001S2T1B1
Fused I/O Termination Block	VE4001S2T1B2
16-Pin Mass Termination Block	VE4001S2T1B3
Discrete Input Card: 8 Channels, 24V DC, Dry Contact	
Standard I/O Termination Block	VE4001S2T2B1**
Redundant Standard I/O Termination Block	VE4031S2T2B1**
Fused I/O Termination Block	VE4001S2T2B2**
16-Pin Mass Termination Block	VE4001S2T2B3**
Discrete Input Card: 32 Channels, 24V DC, Dry Contact	
Standard Termination Block	VE4001S2T2B4
40-pin Mass Termination Block	VE4001S2T2B5
Discrete Input Plus Card: 32 Channels, 24V DC, Dry Contact	
32-Channel DI Terminal Block for Series 2 Plus	VE4001S2T2B6
Redundant 32-Channel DI Terminal Block for Series 2 Plus	VE4031S2T2B6
40-pin DI Mass Termination Block for Series 2 Plus (to be used with DeltaV Signal Conditioning Cards for PLC-5 DI, or P+F HiC IS barriers and terminal boards for DeltaV DCS)	VE4001S2T2B7
40-pin DI Mass Termination Block for Series 2 Plus including 2 x 16-channel DI Plus Mass Connection Boards*	VE4051S2T2B7
Redundant 40-pin DI Mass Termination Block for Series 2 Plus (to be used with DeltaV Signal Conditioning Cards for PLC-5 DI, or P+F HiC IS barriers and terminal boards for DeltaV DCS)	VE4031S2T2B7
Redundant 40-pin DI Mass Termination Block for Series 2 Plus including 2 x 16-channel DI Plus Mass Connection Boards*	VE4081S2T2B7
Discrete Input Card: 8 Channels, 120V AC, Isolated	
Standard I/O Termination Block	VE4001S3T1B1
Fused I/O Termination Block	VE4001S3T1B2
Discrete Input Card: 8 Channels, 120V AC, Dry Contact	
Standard I/O Termination Block	VE4001S3T2B1
Fused I/O Termination Block	VE4001S3T2B2
Pulse Count Input Card: 4-Channels, 24V DC, Dry Contact	
Discrete 32 Channel Terminal Block	VE4015
Sequence of Event Input Card: 16 Channels, 24V DC Dry Contact	
Discrete 32-Channel Terminal Block	VE4001S5T2B4
40-pin Mass Terminal Block	VE4001S5T2B5

*For more details on the Mass Connection Boards and connection cables, please refer to the M-series Mass Connection Solutions PDS.

** Marine certifications are pending; if marine certification is required, please order KJ3201X1-BA1 or KJ3201X1-BA2.

Discrete Output Cards and Termination Blocks	
Description	Model Number
Discrete Output Card: 8 Channels 24V DC, Isolated	
Standard I/O Termination Block	VE4002S1T1B1
Fused I/O Termination Block	VE4002S1T1B2
16-Pin Mass Termination Block	VE4002S1T1B3
Discrete Output Card: 8 Channels 24V DC, High-Side	
Standard I/O Termination Block	VE4002S1T2B1
Redundant Standard I/O Termination Block	VE4032S1T2B1
Fused I/O Termination Block	VE4002S1T2B2
16-Pin Mass Termination Block	VE4002S1T2B3
10-Pin Mass Termination Block	VE4002S1T2B4
Discrete Output Plus Card: 32 Channels, 24 V DC, High-Side	
32-Channel DO Terminal Block for Series 2 Plus	VE4002S2T2B8
Redundant 32-Channel DO Terminal Block for Series 2 Plus	VE4032S2T2B8
40-pin DO Mass Termination Block for Series 2 Plus (to be used with DeltaV Signal Conditioning Cards for PLC-5 DO, or P+F HiC IS barriers and terminal boards for DeltaV DCS)	VE4002S1T2B8
40-pin DO Mass Termination Block for Series 2 Plus including 4 x 8-channel DO Mass Connection Boards*	VE4052S1T2B8
Redundant 40-pin DO Mass Termination Block for Series 2 Plus (to be used with DeltaV Signal Conditioning Cards for PLC-5 DO, or P+F HiC IS barriers and terminal boards for DeltaV DCS)	VE4032S1T2B8
Redundant 40-pin DO Mass Termination Block for Series 2 Plus including 4 x 8-channel DO Mass Connection Boards*	VE4082S1T2B8
Discrete Output Card: 8 Channels 115/230V AC, Isolated	
Standard I/O Termination Block	VE4002S2T1B1
Fused I/O Termination Block	VE4002S2T1B2
Discrete Output Card: 8 Channels 115/230V AC, High-Side	
Standard I/O Termination Block	VE4002S2T2B1
Fused I/O Termination Block	VE4002S2T2B2

*For more details on the Mass Connection Boards and connection cables, please refer to the M-series Mass Connection Solutions PDS.

Spare Part Ordering Information

Spare Parts	
Description	Model Number
250V 2A Fuse for Fused Terminal Block; Box of 20	KJ4010X1-BC1
I/O Module Hold-down Screw; Box of 20	KJ4010X1-BP2
Controller Module Hold-down Screw; box of 20	KJ4010X1-BP3

©2023, Emerson. All rights reserved.

The Emerson logo is a trademark and service mark of Emerson Electric Co. The DeltaV logo is a mark of one of the Emerson family of companies. All other marks are the property of their respective owners.

The contents of this publication are presented for informational purposes only, and while diligent efforts were made to ensure their accuracy, they are not to be construed as warranties or guarantees, express or implied, regarding the products or services described herein or their use or applicability. All sales are governed by our terms and conditions, which are available on request. We reserve the right to modify or improve the designs or specifications of our products at any time without notice.

Contact Us

www.emerson.com/contactus